

# Laser Displacement Distance Sensor User Manual

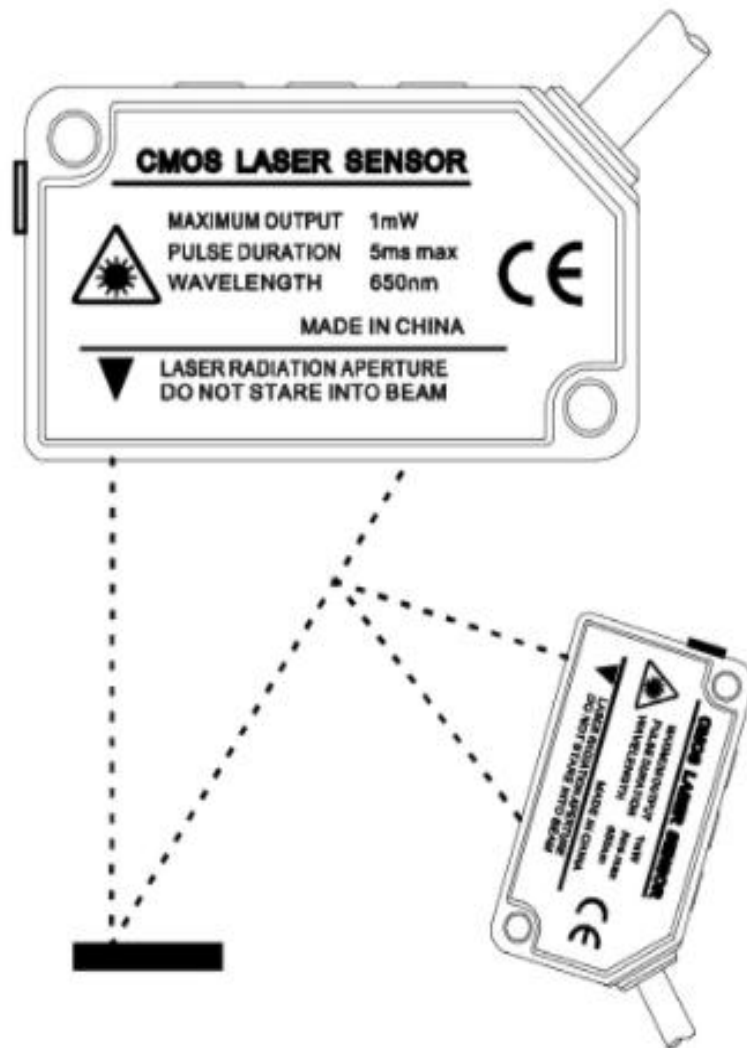

## Warning

- Please read this instruction manual carefully and completely to use this product correctly and reasonably.
- This product is used to inspect (judge, measure) objects. Do not use this product to ensure safety and prevent accidents that may affect life and property.
- This product is dangerous. Do not look directly at the laser or observe the optical system through lenses.



# 1

## Button

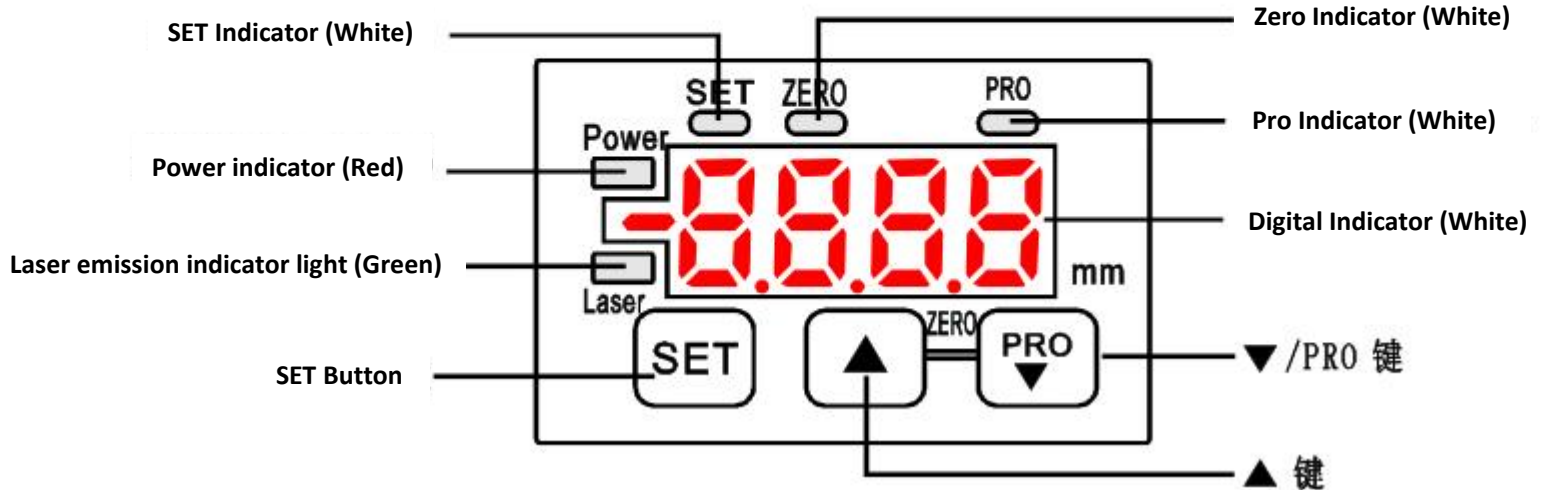

# 2

## Install

- When installing this product, please use M3 screws (please prepare separately). Please use a tightening torque of  $0.5\text{N/m}^2$ .
- When installing this product using the sensor mounting bracket (sold separately), also use a tightening torque of  $0.5\text{N/m}^2$ .

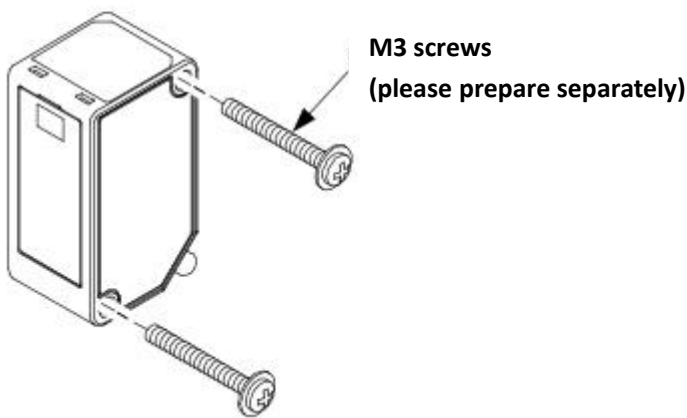

Mounting hole size

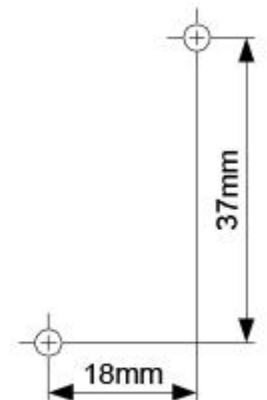

### Installation direction

- Direction relative to the moving object  
<When there is a difference in material or color>
- When measuring, if the material or color of the moving object is extremely different, install it in the direction shown in the figure below to minimize the measurement error.

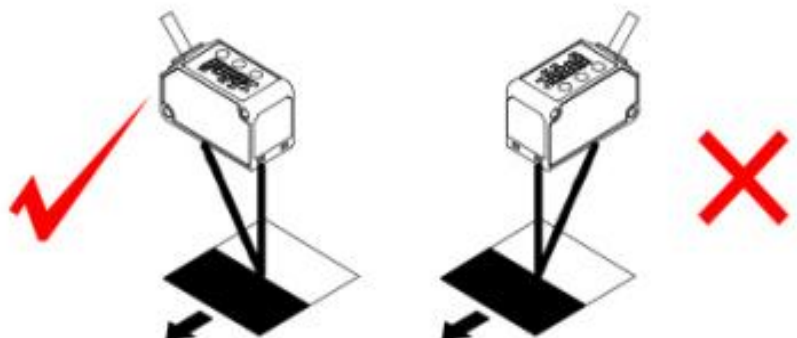

<Measuring a rotating object>

• When measuring a rotating object, install it in the direction shown in the figure below to suppress the influence of vertical vibration and positional deviation of the object.

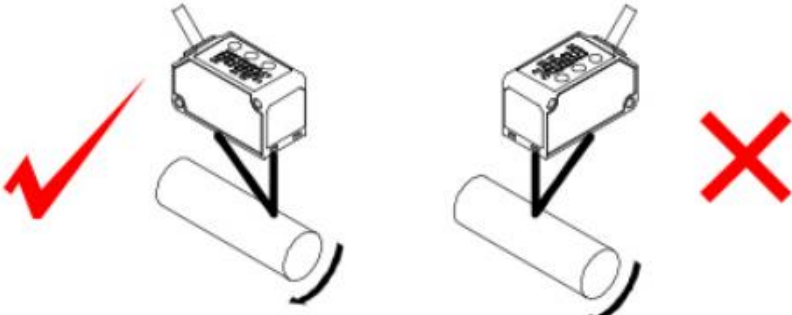

<When there is a step>

When the moving object to be measured has a step, the effect of the step edge can be suppressed by installing it as shown in the figure below.

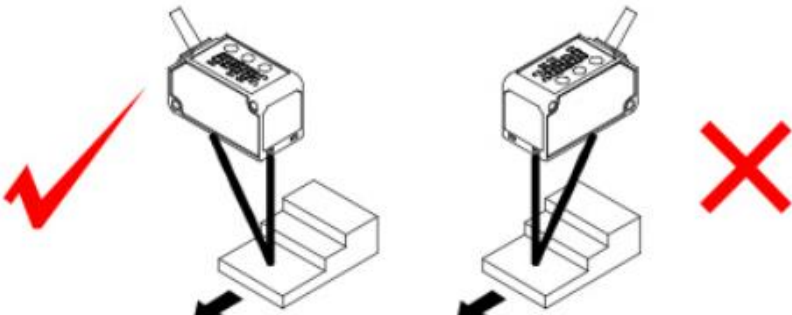

• Measuring in narrow places and recessed parts

When measuring in narrow places and holes, be careful not to block the light path from the light-emitting part to the light-receiving part during installation.

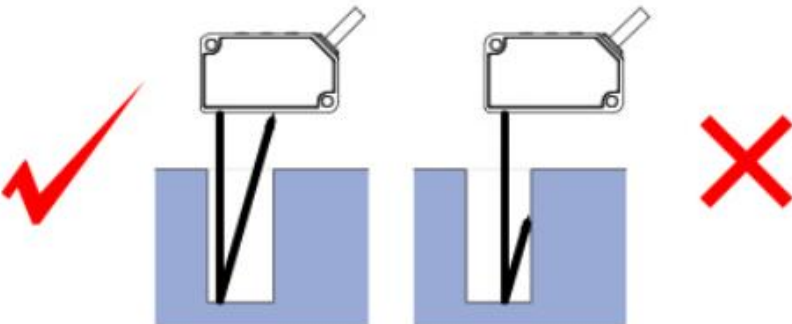

• When installing the sensor on a wall  
Please install it as shown in the figure below to prevent multiple reflections from the wall from entering the light receiving part. In addition, if the reflectivity of the wall is high, it will be more effective if it is changed to matte black.



### 3 Circuit diagram

#### ● NPN Output

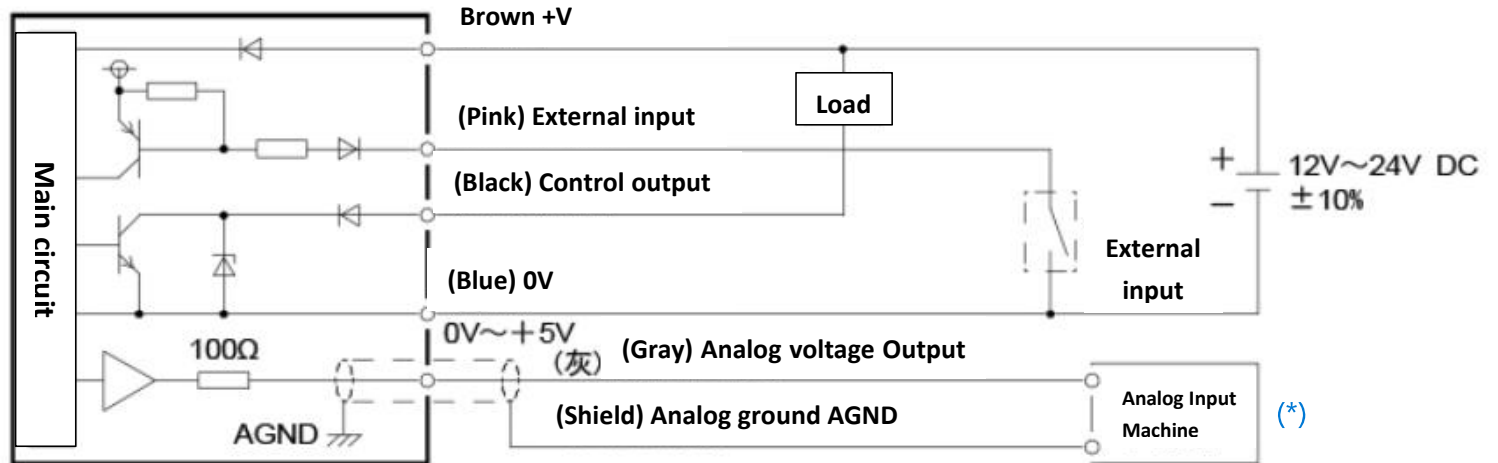

#### ● PNP Output

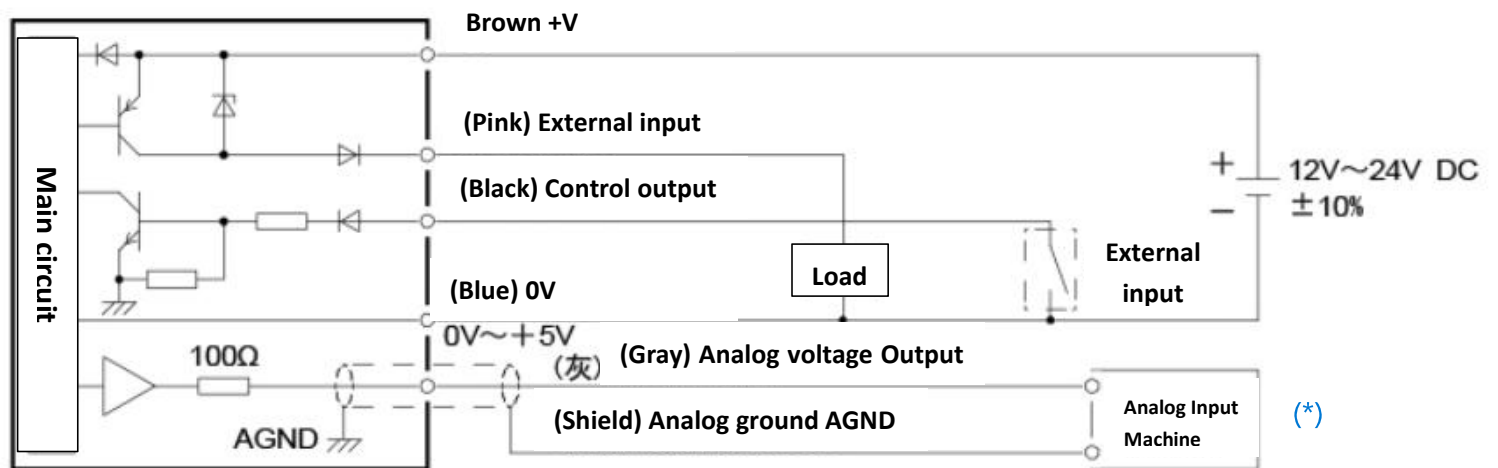

(\*) Refer "RS485 Modbus RTU command Guide" with model LSD-S\*VN

### 4 Setting

#### 2 Point Setting

##### ● Basic Setting Method

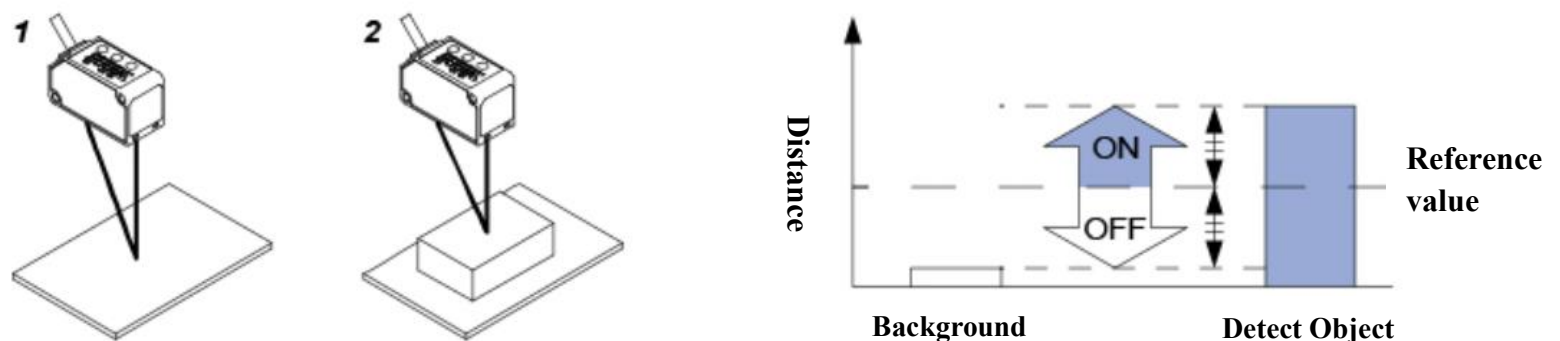

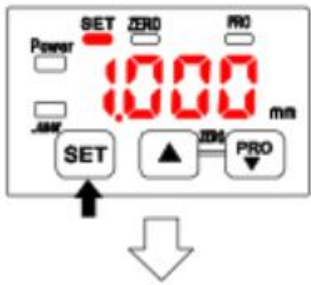

Press the SET button with the background object in place.



Press the SET button with the detected object in place.

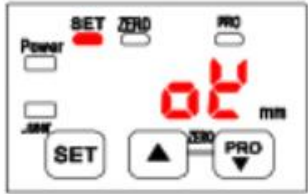

Under stable detection conditions.

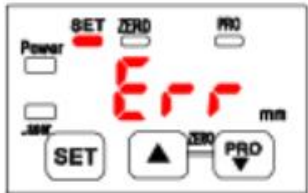

Under unstable detection conditions.

## ■ Limited Setting

. This teaching method is very convenient when there are tiny objects and background objects.

<When the background object is the reference>

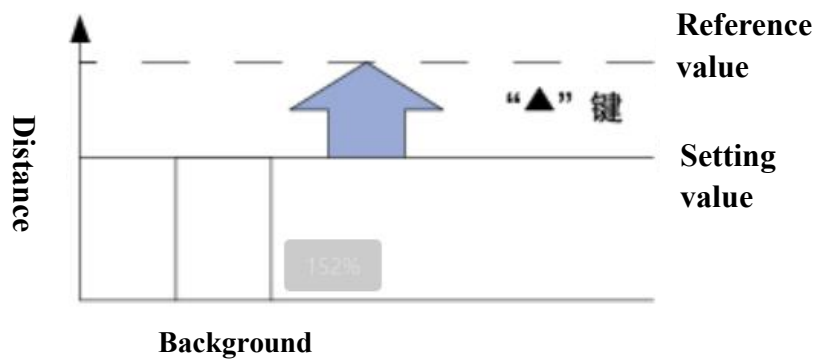
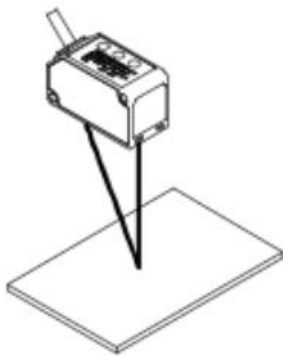

<When the detect object is the reference>

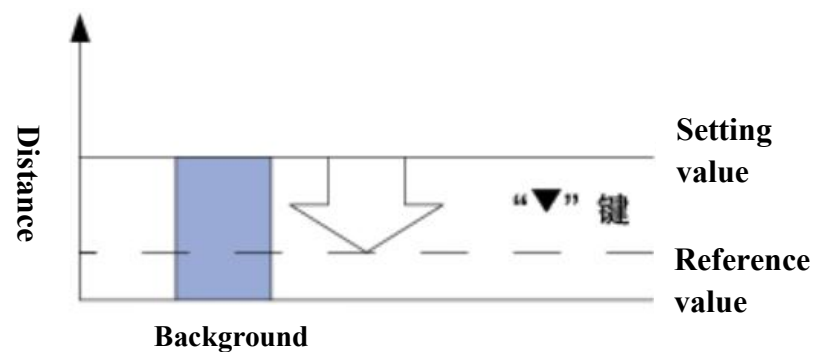
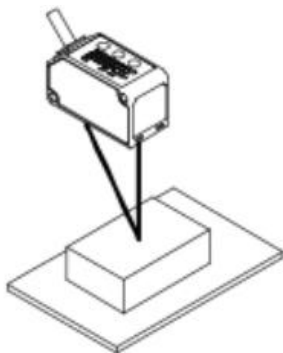



1. Press the SET key when there is a background object or when there is a detection object.

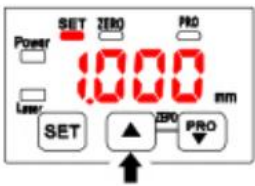

2. When the background object is the reference, press the "▲" key to set the reference value in the sensor.

When the detected object is the reference, press the "▼" key to set the reference value in the detected object.

自动



3. Setup Complete

### ■ 1-point Setting (window comparison mode)

- When the distance to the reference plane of the detection object is not 1-point setting, the upper and lower limits are set. This function is used when judging within the upper and lower limits.
- When implementing 1-point setting (window comparison mode), please set it to [1-point setting (window comparison mode)] in the detection output setting of **PRO** mode in advance.

For the setting method, please refer to "9 PRO mode operation instructions"

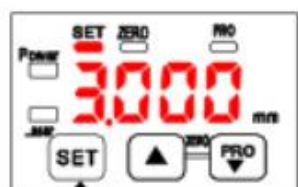
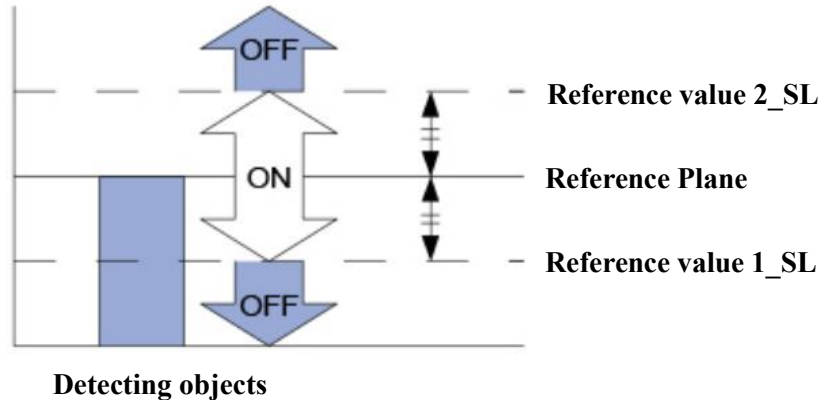

1. With the object to be detected, press the SET button twice (1st time: SET mode, 2nd time: setting)



2. Setup Complete

## ■ 2-point Setting (window comparison mode)

- Execution of Two-Point Setting and Method for Setting the Reference Value Range.
- When implementing two-point setting (window comparator mode), ensure that the detection output setting in **PRO** mode is configured to [Two-Point Setting (Window Comparator Mode)] in advance.

For the setting method, please refer to "9 PRO mode operation instructions"

- When performing setting, use detection objects with different distances (P-1 and P-2).

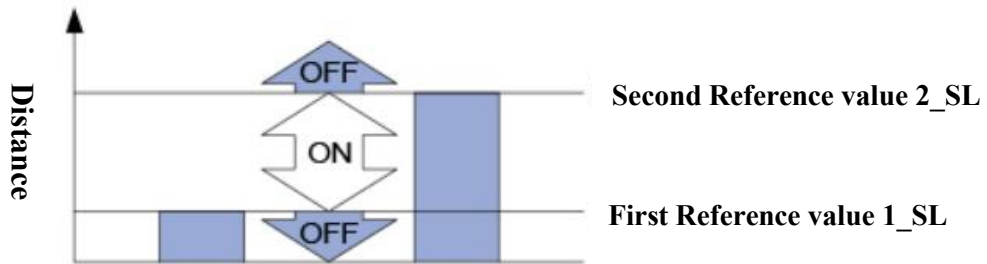

Detecting objects P-1    Detecting objects P-2



1. With the detection object P-1, press the SET key. (1st time)

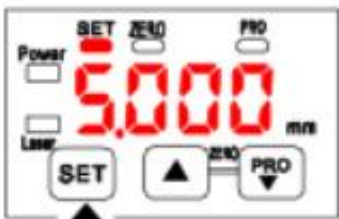

2. With the detection object P-2, press the SET key. (2nd time)

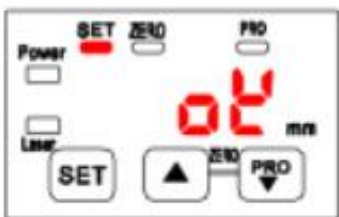

Under stable detection conditions.

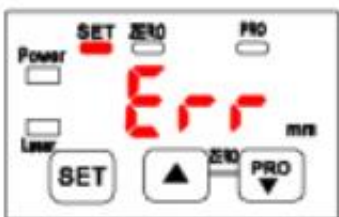

Under unstable detection conditions.

### ■ 3-point Setting (window comparison mode)

• Perform 3-point (P-1, P-2, P-3) Setting. As shown in the figure below, set the reference value 1SL between the 1st and 2nd time, set the reference value 2SL between the 2nd and 3rd time, and set the reference value range.

• When performing 3-point setting (window comparison mode), please set it to [3-point setting (window comparison mode)] in the detection output setting of **PRO** mode in advance.

For the setting method, please refer to "9 PRO mode operation instructions"

When performing setting, use detection objects (P-1, P-2, P-3) with different distances.

• After setting, P-1, P-2, and P-3 will be automatically arranged in order from small to large.

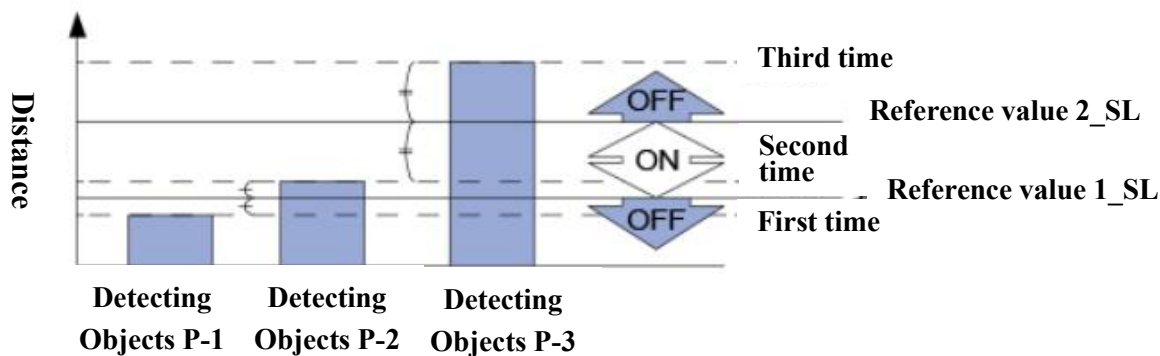

1. With the detection object P-1, press the SET key. (1st time)



2. With the detection object P-2, press the SET key. (2nd time)



3. With the detection object P-3, press the SET key. (3rd time)

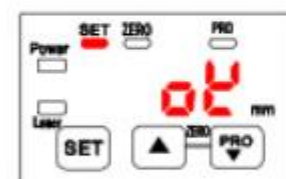

Under stable detection conditions.



Under unstable detection conditions.

## Span adjustment in rising differential mode or falling differential mode

- Cancel the gentle measured value change and use it only when detecting a sharp measured value change. When using the rising differential or falling differential mode, please set the detection output setting of the **PRO** mode to "rising differential" or "falling differential mode" in advance.
- For the setting method, please refer to "9 PRO mode operation instructions"
- When performing setting, use detection objects (P-1, P-2, P-3) with different distances.
- The reference value can be set using the reference value fine-tuning function. For the reference value fine-tuning function, please refer to "5 Reference value fine-tuning function".

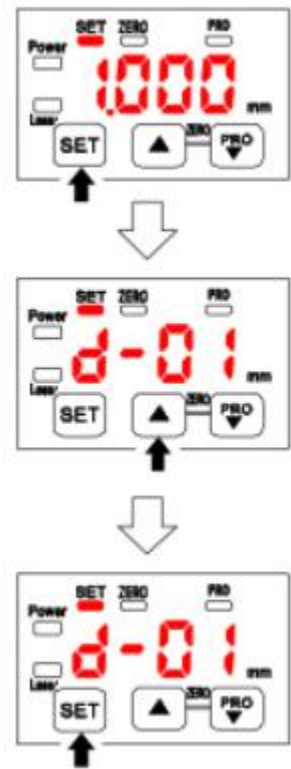

1. Press the SET key1.

2. Press the "▲" key or the "▼" key to select the span.

The span is too short

The span is too long

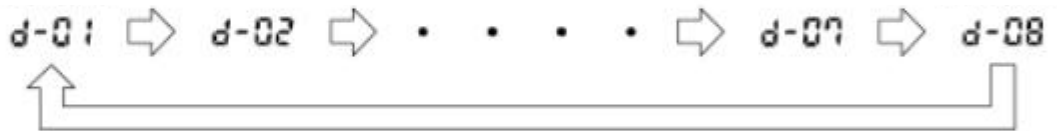

3. Press the SET key to confirm.

## 5 Reference value fine-tuning function

- The reference value can be fine-tuned on the measurement screen.
- The reference value can also be fine-tuned after teaching.

<Normal detection mode, rising differential mode, or falling differential mode>

Press the "▲"/"▼" key

Press the "▲"/"▼" key

Press the "SET" Button



Confirm  
After about 3  
seconds, it will  
be automatically  
confirmed.

<Window comparison mode>

- When the detection output is set to the window comparison mode, press the SET key for 1 second to switch the display between "1\_5L" and "2\_5L".

Press the "SET" Button for 1 Second

Measurement value changes

Measurement screen

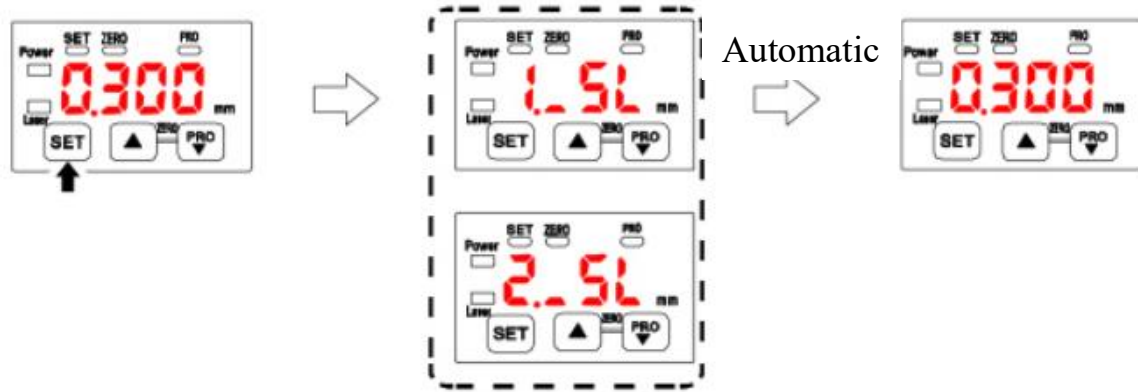

- To fine-tune the reference value of "1\_5L" or "2\_5L", press the "▲" key or the "▼" key. When "1\_5L" or "2\_5L" is displayed, you can fine-tune the reference value.

Press the "▲"/"▼" key

Press the "▲"/"▼" key

Press the "SET" Button

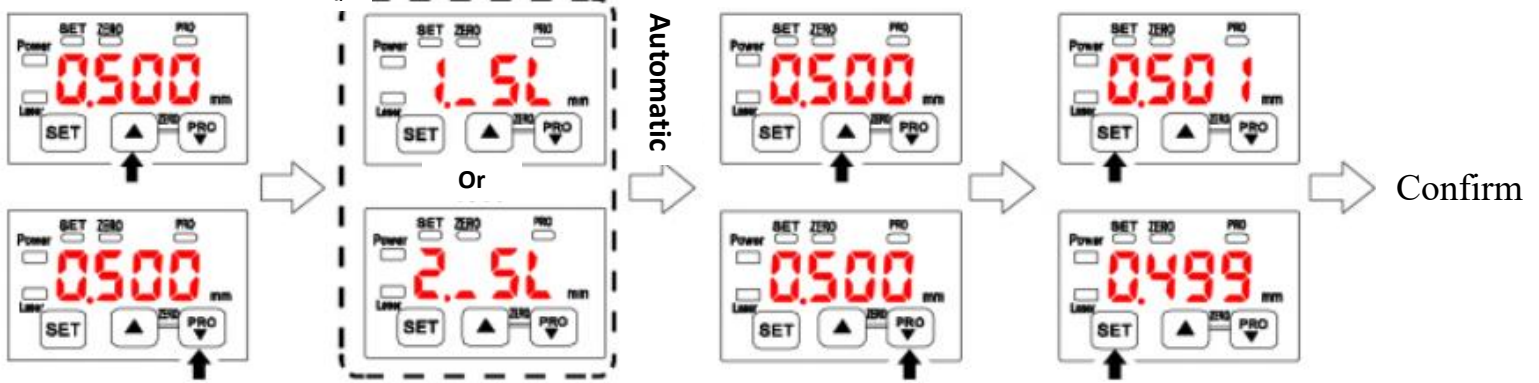

(It will be automatically confirmed after about 3 seconds.)

**6 Peak and valley hold function**

- The peak and valley hold function is a function that displays the peak and valley values.
- When the peak and valley hold function is set to "peak hold" or "valley hold", the measured value held when the zero adjustment function is executed will return to zero.

Press the "SET" and "▼" key for 3 Second

Press the "▲"/"▼" key

Press the "SET" Button

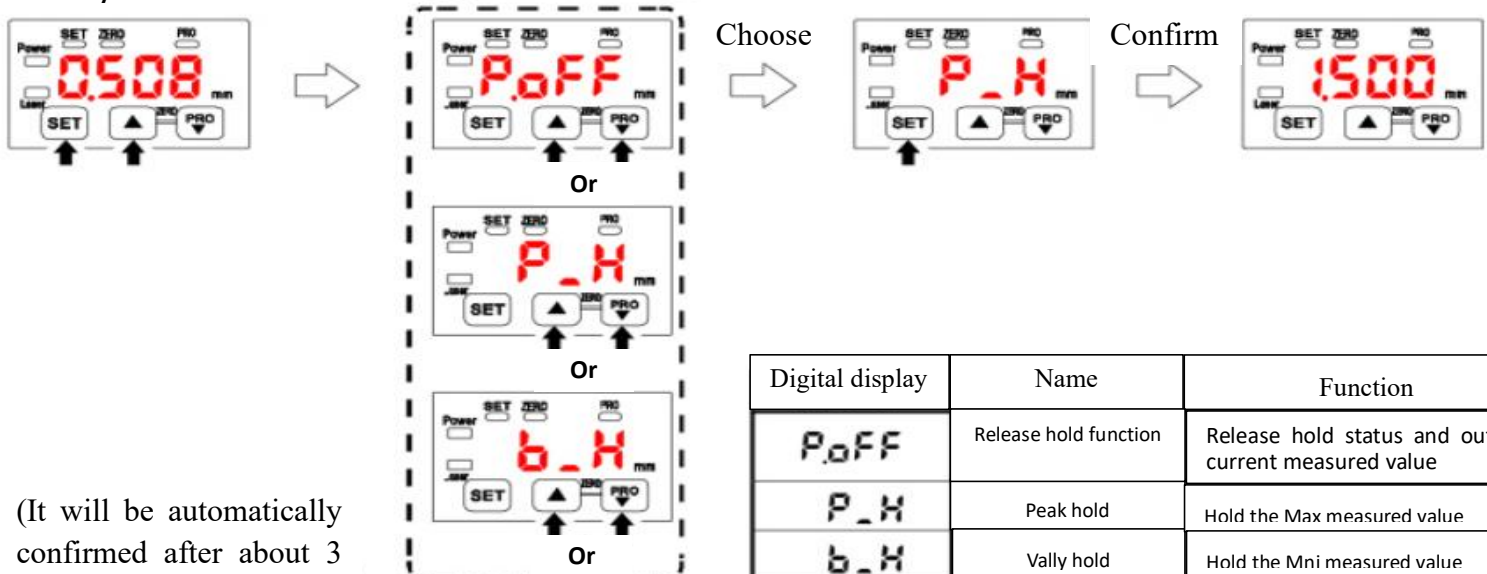

(It will be automatically confirmed after about 3 seconds.)

Digital display	Name	Function
P.OFF	Release hold function	Release hold status and output current measured value
P.H	Peak hold	Hold the Max measured value
V.H	Vally hold	Hold the Mni measured value

- The zero adjustment function is a function that forces the measured value to "zero".
- When setting the zero adjustment, the zero adjustment indicator (red) lights up.
- When the peak and valley hold functions are valid, once the zero adjustment function is executed, the held measured value will be reset.
- When the offset is set, the zero adjustment function cannot be set.

<Zero adjustment setting>

Press the "▲" and "▼" key for 3 Seconds

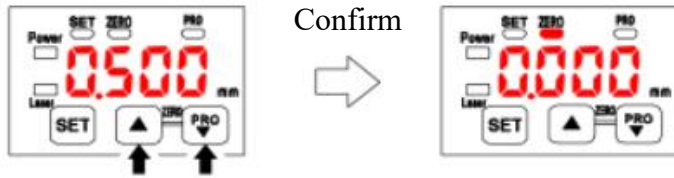

<Release Zero adjustment setting>

Press the "▲" and "▼" key for 6 Seconds

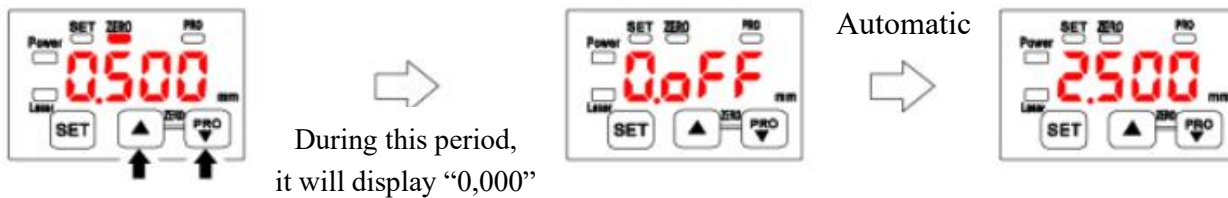

- When the zero adjustment function is set/released by external input, the operation is as shown below.

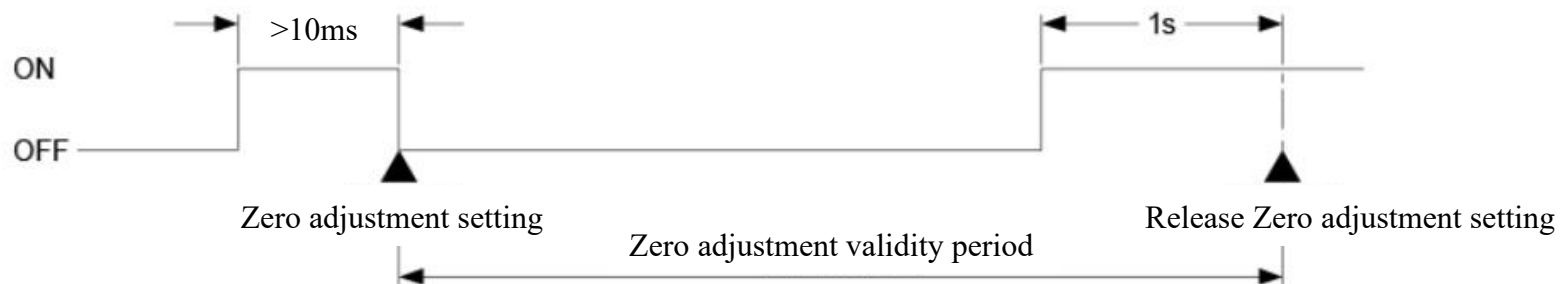

- When the zero setting is set by external input, the setting will be canceled when the power is turned on again. The zero setting cannot be saved at this time.

- Even if the zero setting function is set on the sensor body, the zero setting can be set/cancelled by external input. However, after the power is turned on again, the zero setting set on the sensor body will be displayed.

(※) When saving the setting to the sensor body by external input, the saving is enabled by "external input setting" set in **9 PRO** mode.

## 8

## Key lock function

- The key lock function means that key operations are not accepted to prevent the setting conditions in each setting mode from being changed by mistake.
- After the key lock is set, if a key is operated, "Loc" will appear on the digital display.

<Setting key lock>

Press the "SET" and "▼" key for 3 Seconds



Press the "SET" and "▼" key for 3 Seconds



## 9

## PRO Mode

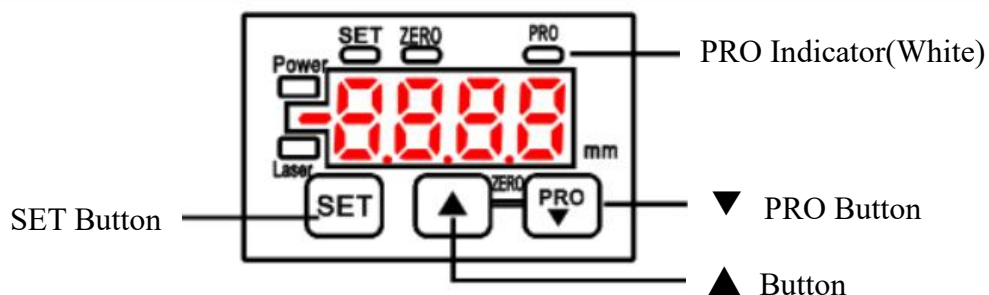

- When the PRO mode is set, the PRO indicator (red) lights up.
- If press the "▼" key for more than 3 seconds during the **PRO** mode setting, the display returns to the measurement screen.

# Setting steps

## Initial measurement



"▼/PRO key": long press for 3 seconds

## Set response time



### High precision



### Standard



### High speed



"▲" / "▼"

## Output action setting

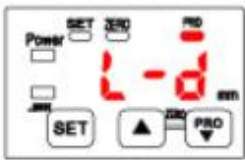

### ON when receiving light



### ON when not receiving light



"▲" / "▼"

## Set detection output

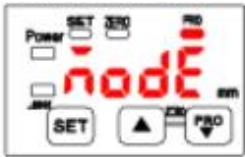

### Standard detection mode

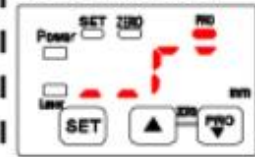

### 3-point teaching (window comparison mode)

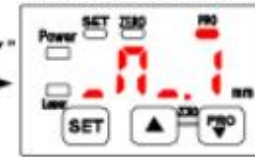

### 2-point teaching (window comparison mode)

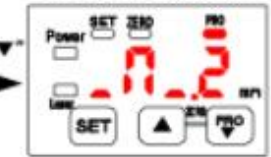

"▲" / "▼"

DOWN  
UP /

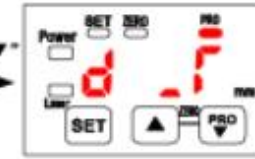
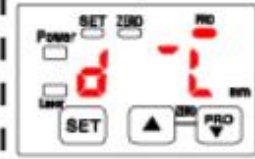

### Rising differential mode

### Falling differential mode

### 1-point teaching (window comparison mode)

Analog output setting    Voltage Analog output    Current Analog output



Hysteresis width



Hysteresis width



▲ Key: Increase hysteresis width  
▼ Key: Decrease hysteresis width

Hysteresis width



Zeroing function



Teaching function



Stop light emission function



Trigger function

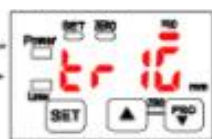

Set timer



No timer



Delay off



Delay on



Single-shot timer

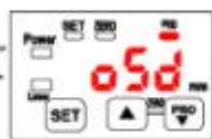

Set display



Normal



Inverted



Offset



Set hold



Hold OFF



Hold ON



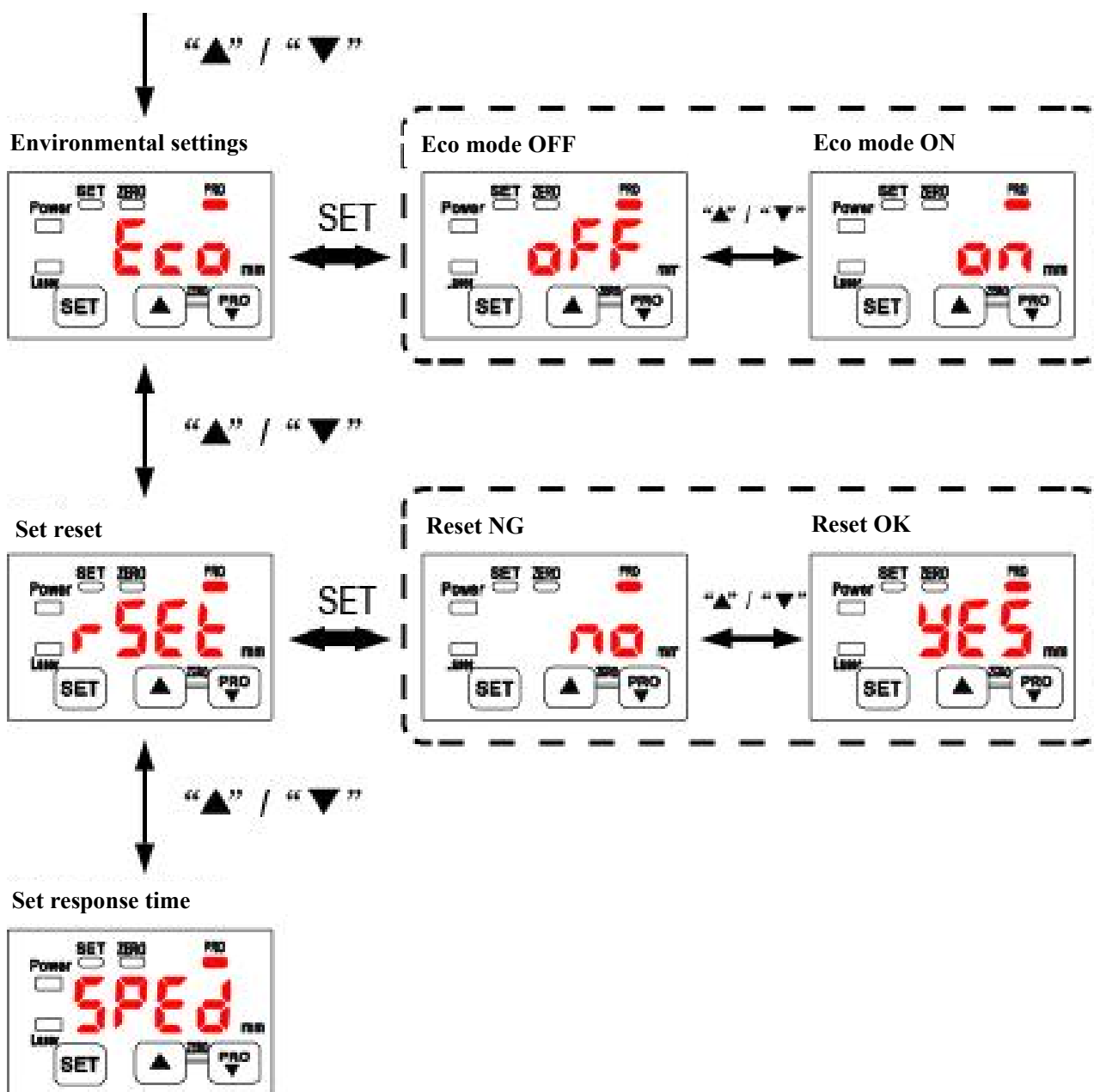

## 10 Error Display

- When an error occurs, take the following actions:

Error display	Content	Action
<p>&lt;Hold OFF&gt;</p> <hr/> <p>&lt;Hold ON&gt;</p> <p>The measured value flashes</p>	The amount of reflected light is insufficient and the detection object is outside the detection range.	<ul style="list-style-type: none"> <li>Please confirm that the detection object is within the measurement range.</li> <li>Please adjust the sensor installation angle.</li> </ul>
<b>E001</b>	The flash memory is damaged or has reached the end of its service life.	Please consult our company.
<b>E011</b>	The load of the detection output is short-circuited and an excessive current is generated.	Please turn off the power and confirm the load.
<b>E021</b>	The semiconductor laser is damaged or has reached the end of its service life.	Please consult our company.
<b>E031</b>	<ul style="list-style-type: none"> <li>During zero adjustment, measurement was not performed properly.</li> <li>The zero adjustment function cannot be used because the display setting is set to offset.</li> </ul>	<ul style="list-style-type: none"> <li>Please confirm that the detection distance is within the specification range.</li> <li>Please set the display setting to something other than offset.</li> </ul>
<b>E041</b>	During setting, measurement was not performed properly.	Please confirm that the detection distance is within the specification range.

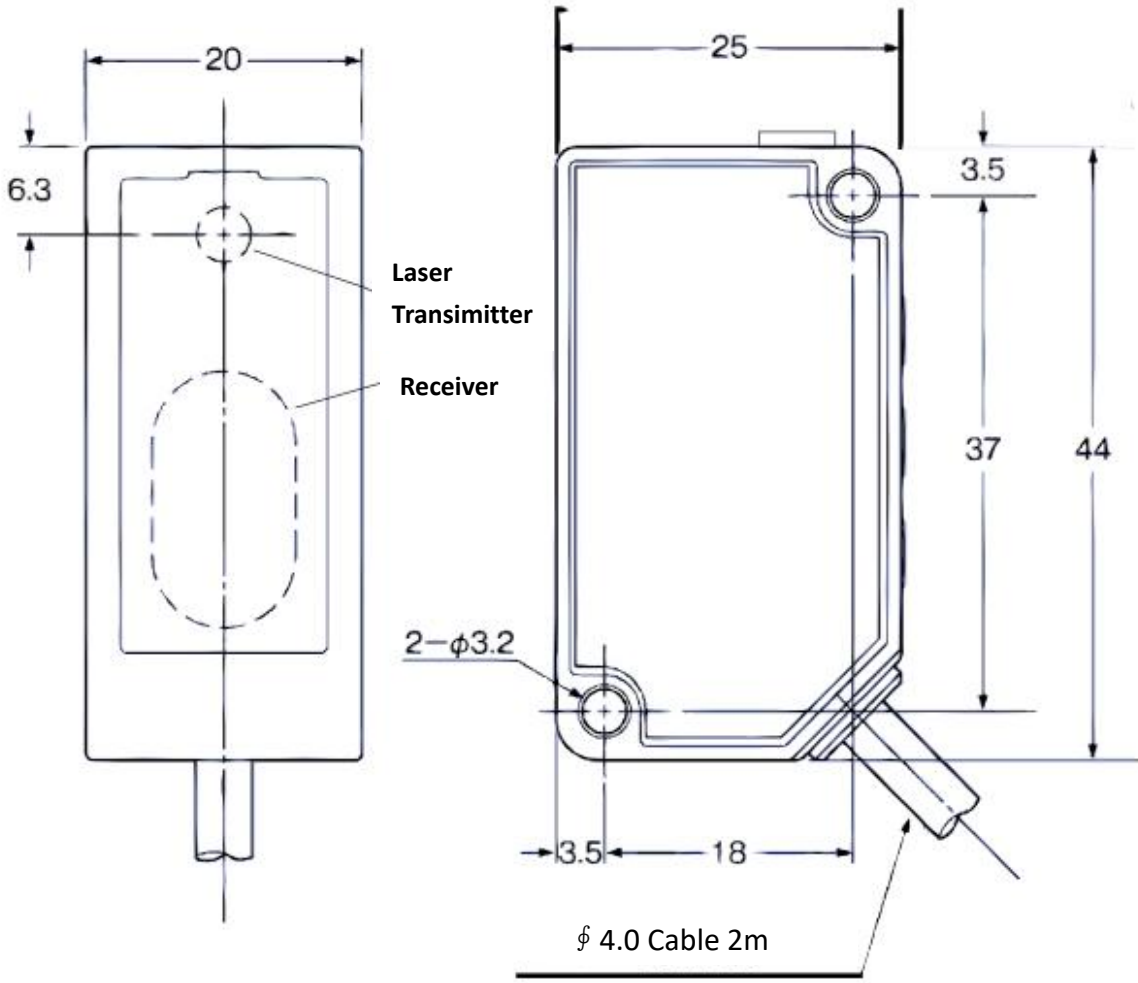

Control Panel

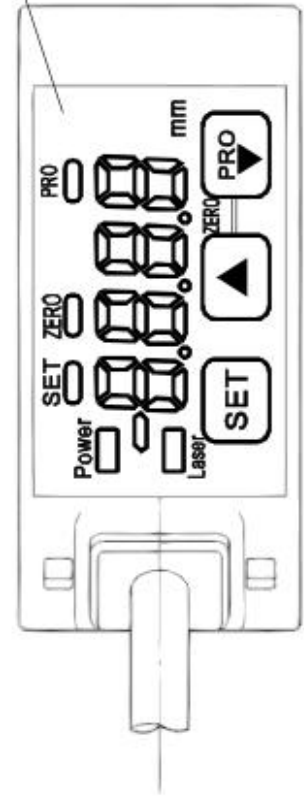

Large output indicator light

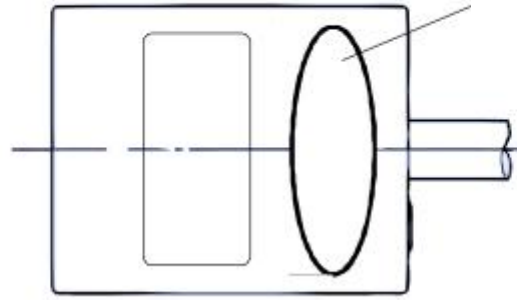

- Isolate the sensor cable from the power line or high-voltage line.
- Do not use the sensor outdoors.
- To prevent dryness or when using a commercial switching regulator, make sure to ground the frame ground terminal and the ground terminal.
- To extend the amplifier cable, use a cable with a cross-sectional area of not less than  $0.3\text{mm}^2$  and a length of not more than 10m.
- The memory write life is about 100,000 times. "ON": When using memory storage, pay attention to the write life.
- Although it varies depending on the type, light from fast-start and high-frequency fluorescent lamps and solar energy may affect detection, so be careful to avoid direct light.
- Do not allow water, oil, fingerprints, etc. that refract light, or dust and garbage that block light to adhere to the light-emitting and light-receiving surfaces of this product. If it is attached, wipe it with a soft cloth that does not generate dust or lens paper.