

PLASTIC FITTINGS (PVDF)



PVDF 90 Degree Elbow Socket /Butt Weld



(SOCKET WELD)

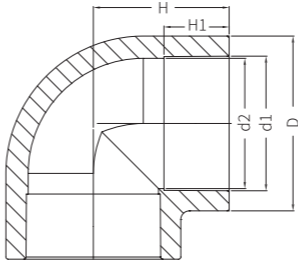

Nominal Size		D	d1	d2	H	H1
1/2"	20mm	28.5	19	17	27	16
3/4"	25mm	34.5	24	22.1	31.6	18
1"	32mm	42.5	31	29.1	37.1	20
1-1/4"	40mm	51.5	39	37.1	43.1	22
1-1/2"	50mm	63.5	49	47	52	26
2"	63mm	80.5	62	60	62.5	30
2-1/2"	75mm	92	73.6	71.6	71.8	33
3"	90mm	113	88.5	86.3	82.2	36
4"	110mm	133	108.5	106.3	98.2	42
5"	140mm					
6"	160mm					
8"	225mm					
10"	280mm					
12"	315mm					



(BUTT WELD)

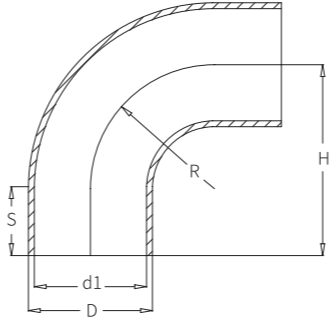

Nominal Size		D	d1 (PVDF)	R	H	S
1/2"	20mm	20	16.2	20	51	33
3/4"	25mm	25	21.2	25	56	33
1"	32mm	32	27.2	32	63	33
1-1/4"	40mm	40	35.2	40	72	36
1-1/2"	50mm	50	44	50	84	36
2"	63mm	63	57	63	97	35
2-1/2"	75mm	75	67.8	75	100	28
3"	90mm	90	81.4	90	123	34
4"	110mm	110	99.4	110	142	34
5"	140mm	140	126.6	140	216	76
6"	160mm	160	144.6	160	316	76
8"	225mm	225	203.4	225	301	76
	250mm	250	226.2	250	323	76
10"	280mm	280	253.2	280	280	146
12"	315mm	315	285	315	321	163

PVDF 45 Degree Elbow Socket /Butt Weld



(SOCKET WELD)

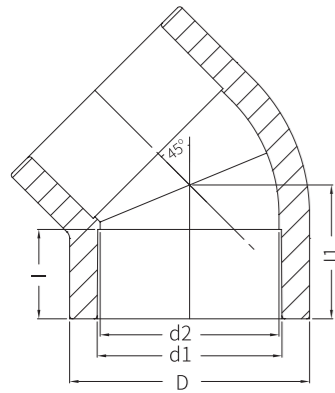

Nominal Size		D	d1	d2	L	L1
1/2"	20mm	28.5	19	17	16	22
3/4"	25mm	34.5	24	22.1	18	25.1
1"	32mm	42.5	31	29.1	20	28.5
1-1/4"	40mm	51.5	39	37.1	22	32.2
1-1/2"	50mm	63.5	49	47	26	38.2
2"	63mm	80.5	62	60	30	44.93
2-1/2"	75mm	92	73.6	71.6	33	50.8
3"	90mm	113	88.5	86.3	36	56.9
4"	110mm	133	108.5	106.3	42	67
5"	140mm					
6"	160mm					
8"	225mm					
10"	280mm					
12"	315mm					



(BUTT WELD)

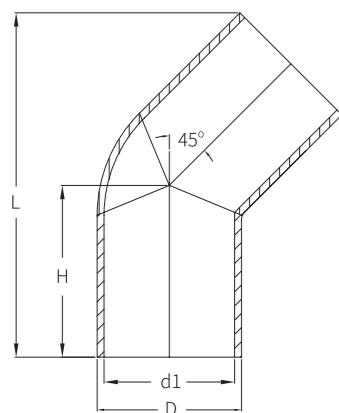

Nominal Size		D	d1 (PVDF)	H	L
1/2"	20mm	20	16.2	43	80.7
3/4"	25mm	25	21.2	45	86
1"	32mm	32	27.2	52	101.2
1-1/4"	40mm	40	35.2	58	113.6
1-1/2"	50mm	50	44	66	131
2"	63mm	63	57	75	150.4
2-1/2"	75mm	75	67.8	83.6	168
3"	90mm	90	81.4	99	198
4"	110mm	110	99.4	119	242
5"	140mm	140	126.6	151	306
6"	160mm	160	144.6	177	354
8"	225mm	225	203.4	251	498
	250mm	250	226.2	281	562
10"	280mm	280	253.2	319	636
12"	315mm	315	285	363	726

PVDF Equal Tee Socket /Butt Weld



(SOCKET WELD)

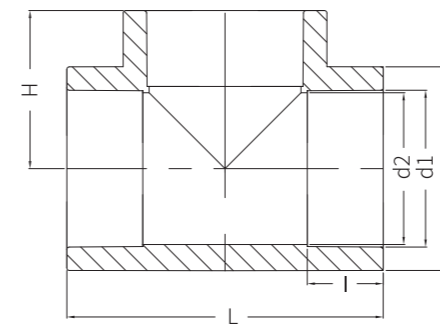

Nominal Size		D	d1	d2	H	L	I
1/2"	20mm	28.5	19	17	27	54	16
3/4"	25mm	34.5	24	22.1	31.55	63.1	18
1"	32mm	42.5	31	29.1	37.05	74.1	20
1-1/4"	40mm	51.5	39	37.1	43.05	86.1	22
1-1/2"	50mm	63.5	49	47	52	104	26
2"	63mm	80.5	62	60	62.5	125	30
2-1/2"	75mm	92	73.5	71.6	71.8	143.6	33
3"	90mm	113	88.5	86.3	85.2	164.3	36
4"	110mm	133	108.5	106.3	98.2	196.3	42
5"	140mm						
6"	160mm						
8"	225mm						
10"	280mm						
12"	315mm						



(BUTT WELD)

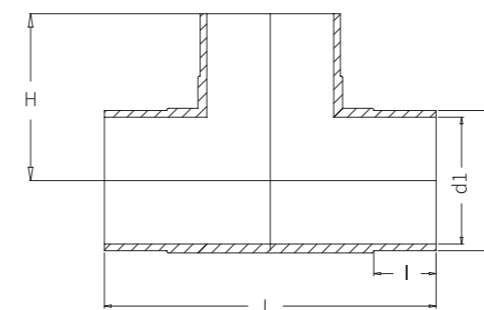

Nominal Size		D	d1 (PVDF)	H	L	I
1/2"	20mm	20	16.2	35	70	15
3/4"	25mm	25	21.2	40	80	15
1"	32mm	32	27.2	45	89	17
1-1/4"	40mm	40	35.2	50	100	16
1-1/2"	50mm	50	44	60	120	23
2"	63mm	63	57	75	149	28
2-1/2"	75mm	75	67.8	87	175	28
3"	90mm	90	81.4	92	181	33
4"	110mm	110	99.4	110	223	33
	125mm	125	113	114.5	278	52
5"	140mm	140	126.6	133.5	280	63.5
6"	160mm	160	144.6	160	320	74.5
	180mm	180	162.8	170	400	80
	200mm	200	180.8	189	446	89
8"	225mm	225	203.4	201.5	440	94
	250mm	250	226.2	195	418	45
10"	280mm	280	253.2	210	636	70
12"	315mm	315	285	227	706	70

PVDF Coupling Socket /Butt Weld

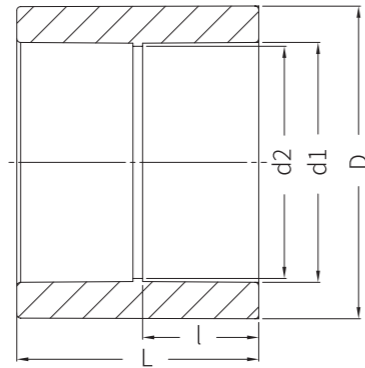

(SOCKET WELD)

Nominal Size	D	d1	d2	L	I
1/2"	20mm	19	17	34.5	16
3/4"	25mm	24	22.1	38.5	18
1"	32mm	31	29.1	42.5	20
1-1/4"	40mm	39	37.1	46.5	22
1-1/2"	50mm	49	47	54.5	26
2"	63mm	62	60	62.5	30
2-1/2"	75mm	73.5	71.6	71	33
3"	90mm	88	86.3	78	36
4"	110mm	108.5	106.3	90	42
5"	140mm				
6"	160mm				
8"	225mm				
10"	280mm				
12"	315mm				

PVDF End Cap Socket /Butt Weld



(SOCKET WELD)

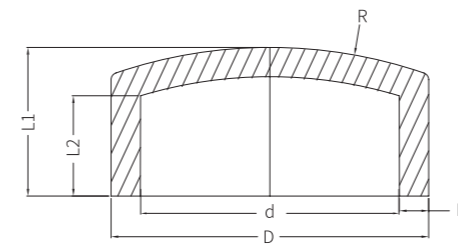

Nominal Size	1/2"	3/4"	1"	1-1/4"	1-1/2"	2"	2-1/2"	3"	4"
	20mm	25mm	32mm	40mm	50mm	63mm	75mm	90mm	110mm
d	19	24	31	39	49	62	73.6	88.5	108.5
D	28.5	34.5	42.5	51.5	63.5	80	92	113	133
L1	16	18	20	22	26	30	32.91	36.1	42
L2	20.94	23.69	27.35	31.7	36.08	41.82	48.2	55.25	62.25
L3	4.75	5.25	5.75	6.25	7.25	9	9.2	12.25	12.25
R	3	3	3	3	3	3	3	3	3



(BUTT WELD)

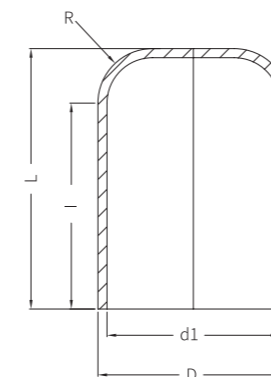

Nominal Size	D	d1 (PVDF)	L	I	R
1/2"	20mm	20	16.2	45	41
3/4"	25mm	25	21.2	49	41
1"	32mm	32	27.2	56	45
1-1/4"	40mm	40	35.2	64	50
1-1/2"	50mm	50	44	73	60
2"	63mm	63	57	86	68
2-1/2"	75mm	75	67.8	93	75
3"	90mm	90	81.4	110	84
4"	110mm	110	99.4	125	99

PVDF Male Adapter Socket /Butt Weld



(SOCKET WELD)

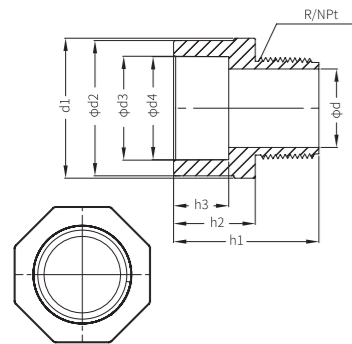

Nominal Size		d	d1	d2	d3	d4	h1	h2	h3	R
1/2"	20mm	13.3	30.68	28.68	18.99	18.6	41.5	22.5	19	NPT
3/4"	25mm	17	36.7	34.7	23.99	23.7	44.5	28	20	NPT
1"	32mm	23.3	44.72	42.72	30.99	30.7	55	32.5	23	NPT
1-1/4"	40mm	29.5	53.5	51.5	38.99	38.7	59	34	25	NPT
1-1/2"	50mm	37	66	63.79	48.99	48.6	68.5	40	30	NPT
2"	63mm	48.3	83	80.83	61.99	61.6	75.5	43	33	NPT



(BUTT WELD)

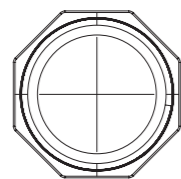
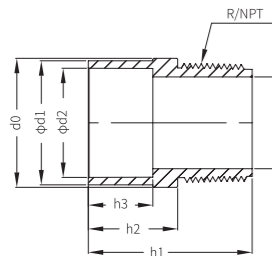

Nominal Size		d0	d1	d2(PVDF)	d3	h1	h2	h3	R
1/2"	20mm	25	20.05	16.2	13.3	47	27	19	NPT
3/4"	25mm	28	25.05	21.2	17	48	28	20	NPT
1"	32mm	35	32.05	27.2	23.3	58.5	32.5	23	NPT
1-1/4"	40mm	43	40	35.2	29.5	60.5	34.5	25	NPT
1-1/2"	50mm	52	50	44	37	66	40	30	NPT
2"	63mm	65	63	57	48.3	73	40	30	NPT

PVDF Female Adapter Socket /Butt Weld



(SOCKET WELD)

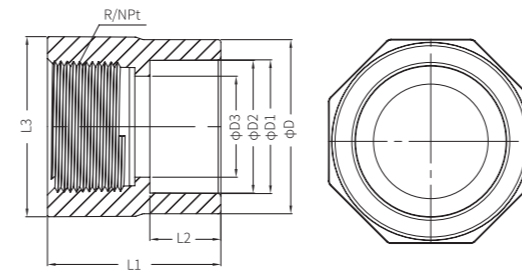

Nominal Size		D	D1	D2	D3	L1	L2	L3	R
1/2"	20mm	28.5	18.99	18.6	13.3	39	16	31.79	NPT
3/4"	25mm	34.51	23.99	23.7	17	42	25.4	36.99	NPT
1"	32mm	42.5	31.14	30.85	23.3	46.87	20	44.39	NPT
1-1/4"	40mm	51.5	38.99	38.7	29.5	55.98	22	55.91	NPT
1-1/2"	50mm	63.79	48.98	48.6	37	63.5	26	65.99	NPT
2"	63mm	80.83	61.99	61.6	48.3	68.5	30	83	NPT



(BUTT WELD)

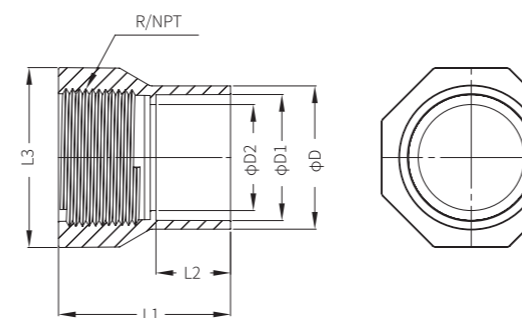

Nominal Size		D	D1 (PVDF)	D2	L1	L2	L3	R
1/2"	20mm	20.05	16.15	13.3	41	20	31.83	NPT
3/4"	25mm	25.05	21.15	17	44	20	35.04	NPT
1"	32mm	32.05	27.2	23.3	53	26.13	44.42	NPT
1-1/4"	40mm	40	35.2	29.5	58	26	55.91	NPT
1-1/2"	50mm	50	44	37	60	26	62.79	NPT
2"	63mm	63	57	48.3	70	33	76.65	NPT

PVDF Reducer Coupling Socket /Butt Weld



(SOCKET WELD)

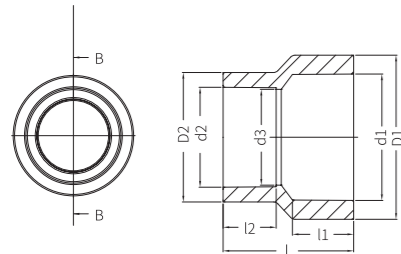

Size	D1	D2	d1	d2	d3	L	I1	I2
25x16	34.5	22	24	15	13.4	40	18	15
25x20	34.5	28.5	24	19	17	40	18	17
32x20	42.5	28.5	31	19	17	44.5	20	17.5
32x25	42.5	34.5	31	24	22	44.5	20	18.5
40x20	51.5	28.5	39	19	17	50	22	16
40x25	51.5	34.5	39	24	22.1	50	22	18
40x32	51.5	42.5	39	31	29.1	50	22	20
50x20	63.5	28.5	49	19	17	60	25.5	16.5
50x25	63.5	34.5	49	24	22.1	58.5	25.5	17.5
50x32	63.5	42.5	49	31	29.1	57	25.5	21
50x40	63.5	51.5	49	39	37.1	55	25.5	22
63x20	80.5	28.5	62	19	17	74	30	17
63x25	80.5	34.5	62	24	22.1	74.5	30	19
63x32	80.5	42.5	62	31	19.1	74	30	21
63x40	80.5	51.5	62	39	37.1	70	30	21
63x50	80.5	63.5	62	49	47	65	30	26
75x63	92	80.8	73.5	62	60	74	34	30.5
90x63	113	92	88	62	60	88	37	30
90x75	113	92	88	73.5	71.6	88	36	33
110x63	133	80.8	107.5	62	60	90	42	30
110x75	133	92	107.5	73.5	71.6	90	42	34
110x90	133	113	107.5	88	86.3	90	42	36

PVDF Reducing Tee Socket /Butt Weld



(SOCKET WELD)

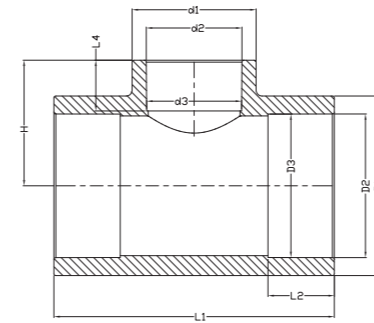

Nominal Size	D1	D2	D3	d1	d2	d3	L1	L2	L3	L4
25*20	34.57	24.04	22.14	34.57	19.02	17.89	63.22	18.04	31.61	16
32*20	42.84	31.05	29.16	28.56	19.02	17.03	74.25	20.04	32.8	15.7
32*25	42.84	31.05	29.16	34.57	24.04	22.14	74.25	20.04	35.16	18
40*20	51.9	39.06	37.17	28.56	19.02	17.03	86.27	22.04	37.14	16
40*25	51.9	39.06	37.17	34.57	24.04	22.14	86.27	22.04	39.11	18
40*32	51.9	39.06	37.17	42.58	31.05	29.16	86.27	22.04	41.07	20
50*20	63.62	49.08	47.09	28.56	19.02	17.03	104.2	26.05	42.08	16
50*25	63.62	49.08	47.09	34.57	24.04	22.14	104.2	26.05	44.05	18
50*32	63.62	49.08	47.09	42.58	31.05	29.16	104.2	26.05	46.11	20
50*40	63.62	49.08	47.09	51.6	39.06	37.17	104.2	26.05	48.08	22
63*20	80.66	62.11	60.12	28.56	19.02	17.03	125.25	30.06	48.58	16
63*25	80.66	62.11	60.12	34.57	24.04	22.14	125.25	30.06	50.64	18
63*32	80.66	62.11	60.12	42.58	31.05	29.16	125.25	30.06	52.6	20
63*40	80.66	62.11	60.12	55.53	39.77	37.84	125.25	30.06	55.55	22.4
63*50	80.66	62.11	60.12	63.62	49.08	47.09	125.25	30.06	58.6	26
75*50	92.18	73.74	71.74	63.62	49.08	47.09	143.88	34.05	64.48	26
75*63	92.18	73.74	71.74	80.6	62.11	60.12	143.88	34.05	68.5	30
90*32	113.22	88.67	86.47	42.58	31.05	29.16	164.62	37.05	66.1	20
90*40	113.22	88.67	86.47	51.6	39.1	37.2	164.62	37.05	67.58	22
90*50	113.22	88.67	86.47	63.62	49.08	47.09	164.62	37.05	71.75	26
90*63	113.22	88.67	86.47	80.66	62.11	60.12	164.62	37.05	75.73	30
90*75	113.22	88.67	86.47	92.18	73.74	71.74	164.62	37.05	79.86	34
110*63	133	108.5	106.3	80.5	62.11	60	194.3	41	85.57	30
110*75	133	108.5	106.3	92	73.6	71.6	194.3	41	89.5	34
110*90	133	108.5	106.3	113	88.49	86.3	194.3	41	93.43	37



(BUTT WELD)

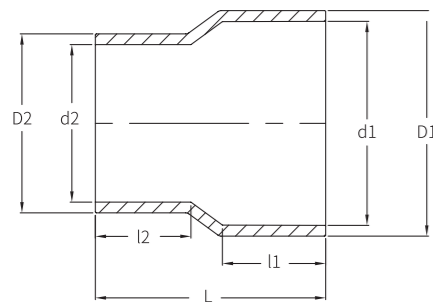

Size	D1	d1 (PVDF)	D2	d2 (PVDF)	L	I1	I2
20x16	20	16.2	16	12.2	50	20.2	19.8
25x20	25	21.2	20	16.2	50	20.3	19.8
32x20	32	27.2	20	16.2	50	25.4	19.8
32x25	32	27.2	25	21.2	50	25.4	20.0
40x20	40	35.2	20	16.2	55	25.5	20.0
40x25	40	35.2	25	21.2	55	25.5	20.0
40x32	40	35.2	32	27.2	55	26.0	25.5
50x20	50	44	20	16.2	60	26.0	20.2
50x25	50	44	25	21.2	60	26.0	19.8
50x32	50	44	32	27.2	60	26.0	25.0
50x40	50	44	40	35.2	60	26.0	26.3
63x20	63	57	40	21.2	65	29.3	20.0
63x25	63	57	25	21.2	65	29.8	19.0
63x32	63	57	32	27.2	65	30.5	26.5
63x40	63	57	40	35.2	65	30.2	25.4
63x50	63	57	50	44	65	30.0	25.8
75x50	75	67.8	50	44	147	67	50
75x63	75	67.8	63	57	147	67	50
90x50	90	81.4	50	44	161	76	55
90x63	90	81.4	63	57	162.5	76	55
90x75	90	81.4	75	67.8	161	76	55
110x63	110	99.4	63	57	180	79	70
110x75	110	99.4	75	67.8	180	79	70
110x90	110	99.4	90	81.4	180	80	70
140x63	140	126.6	63	57	127	55	45
140x75	140	126.6	75	67.8	127	55	50
140x90	140	126.6	90	81.4	128	55	50
140x110	140	126.6	110	99.4	128	55	55</

PVDF One Piece Flange Socket /Butt Weld



(SOCKET WELD)

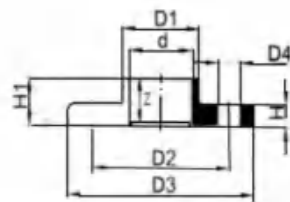

Size Dimension	PN	Code	d mm	D1 mm	D2 mm	D3 mm	D4 mm	H mm	H1 mm	z mm
20	16	11011402001	19.2	29	64	93	13	13	20	16
5 2	16	11011402501	24.2	35	73	103	13	17	24	19
32	16	11011403201	31.1	42	83	103	13	17	22	19
40	16	11011404001	39.0	52	94	137	13	20	30	25
50	16	11011405001	48.9	65	107	147	17	20	31	23
63	16	11011406301	61.9	82	122	162	17	25	38	28
75	16	11011407501	73.7	97	142	182	17	24	42	30
90	16	11011409001	88.6	102	158	198	17	27	49	40
110	16	11011411001	108.4	132	177	217	17	28	60	50

PVDF Van Stone Flange Socket /Butt Weld



(SOCKET WELD)

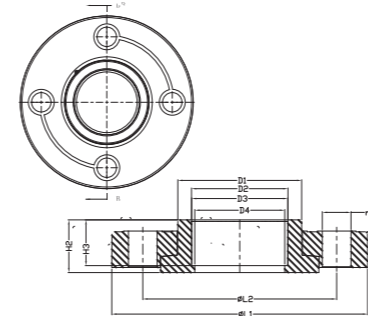

Size	D1	D2	D3	D4	H1	H2	H3	øL1	øL2	n-øe	
1/2"	20mm	28	19.28	19	15	16.5	27.75	23.26	95.8	65.65	15.15
3/4"	25mm	34	24.24	24	20	16.5	26.97	22.48	105.89	75.75	15.15
1"	32mm	42	31.24	31	27	17.5	29.11	24.62	116	85	15.15
1-1/4"	40mm	51	39.24	39	35	18	30.9	26.41	140	100	18.5
1-1/2"	50mm	62	49.22	49	44	21	34.09	29.6	150	110	18.5
2"	63mm	79.84	62.19	62	58	23	34	29.51	165	125	18.5
2-1/2"	75mm	89.73	73.6	73.5	70	25.5	38	34	186	145	18
3"	90mm	108.71	88.5	88.3	85	26.5	41	37	201	160	18
4"	110mm	130.66	108.5	108.3	105	27.5	47	42	221	180	18



(BUTT WELD)

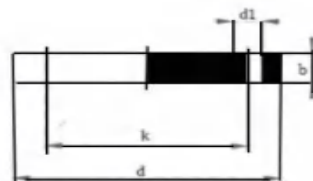

Size Dimension	PN	d mm	d1 mm	b mm	k mm
20	16	95	14	12	65
25	16	105	14	15	75
32	16	115	14	18	85
40	16	140	18	18	100
50	16	150	18	21	110
63	16	165	18	25	125
75	16	185	18	26	145
90	16	200	18	26	160
110	16	220	18	27	180



(BUTT WELD)

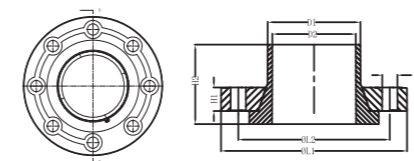

Size	D1	D2 (pvdf)	H1	H2	øL1	øL2	n-øe	
1/2"	20mm	20	16.2	12	50	96	45	15.15
3/4"	25mm	25	21.2	12	52	106	58	15.15
1"	32mm	32	27.2	16	54	116	68	15.15
1-1/4"	40mm	40	35.2	20	56	140	78	18.5
1-1/2"	50mm	50	44	21	62	150	88	18.5
2"	63mm	63	57	23	63	165	102	18.5
2-1/2"	75mm	75	67.8	25	66	186	122	18
3"	90mm	90	81.4	26.5	81.5	201	138	18
4"	110mm	110	99.4	27.5	81.5	221	158	18
5"	140mm	140.15	126.6	30	97.45	254	188	22
6"	160mm	160.15	144.6	30	109.45	280	212	23
8"	225mm	225.15	203.4	32	134	335	295	22
	250mm	250	226.2	27	100	394	350	23
10"	280mm	280	253.2	27	100	399	350	23
12"	315mm	315	285	34	100	449	400	23